

Model TFP PH2 — 5.6 K-factor Institutional Pendent Sprinklers Standard Response, Standard Coverage

General Description

The TYCO Model TFP PH2, 5.6 K-factor, Institutional Pendent Sprinklers are standard response standard coverage, fusible solder type spray sprinklers designed for use in areas such as correctional, detention, and mental health care facilities.

The unique features of the Model TFP PH2 provide a tamper resistant sprinkler design that helps eliminate the opportunity for individuals to injure themselves or others with the components of a fire sprinkler. At the same time, the Model TFP PH2 optimizes an aesthetically appealing flush design that conceals most of the operating parts.

NOTICE

The Model TFP PH2 Institutional Pendent Sprinklers described herein must be installed and maintained in compliance with this document, as well as with the applicable standards of the NATIONAL FIRE PROTECTION ASSOCIATION, in addition to the standards of any other authorities having jurisdiction. Failure to do so may impair the performance of these devices.

The owner is responsible for maintaining their fire protection system and devices in proper operating condition. Contact the installing contractor or product manufacturer with any questions.

IMPORTANT

Refer to Technical Data Sheet TFP2300 for warnings pertaining to regulatory and health information.

Always refer to Technical Data Sheet TFP700 for the "INSTALLER WARNING" that provides cautions with respect to handling and installation of sprinkler systems and components. Improper handling and installation can permanently damage a sprinkler system or its components and cause the sprinkler to fail to operate in a fire situation or cause it to operate prematurely.

Sprinkler Identification Number (SIN)

TY3290

Technical Data

Approvals

UL and C-UL Listed
NYC under MEA 351-01-E
(Refer to the Design Criteria section.)

Maximum Working Pressure

175 psi (12,1 bar)

Inlet Thread Connection

1/2 in. NPT

Discharge Coefficient

K=5.6 GPM/psi^{1/2} (80,6 LPM/bar^{1/2})

Temperature Ratings

165°F (74°C) or
212°F (100°C)

Finishes

Sprinkler: Chrome Plated
Escutcheon: Chrome Plated

Physical Characteristics

Body	Brass
Deflector	Bronze
Deflector Reinforcement	Bronze
Deflector Post	Bronze
Deflector Post Pin	Bronze
Deflector Core	Bronze
Compression Screw	Bronze
Lever	Bronze
Release Spring	Bronze
Core Sleeve	Copper
Sealing Assembly ..	Beryllium Nickel w/ TEFLON
Dust Cover	Chrome Plated Steel
Fusible Element	Solder, Copper, Stainless Steel



Operation

In the standby condition, the design of the Model TFP PH2 is such that a dynamic load of 80 lb (36 kg) or more applied to the linkage mechanism will release the sprinkler. Also, when properly installed, the escutcheon is held fast to the ceiling to deter its removal. The shape of the escutcheon cannot be easily grasped, which further deters tampering.

A fusible solder operating element secures the linkage mechanism of the Model TFP PH2. When the rated temperature is reached, the solder melts, releasing the linkage mechanism that holds the sprinkler closed. This allows the deflector to extend downward and water to flow.

Design Criteria

The TYCO Model TFP PH2, 5.6 K-factor, Institutional Pendent Sprinklers (TY3290) are intended for use with fire protection systems designed in accordance with the standard installation rules recognized by the applicable Listing or Approval agency (for example, Listing is based on NFPA 13 requirements).

Components:

- 1 - Body
- 2 - Deflector
- 3 - Deflector Reinforcement
- 4 - Deflector Post (2 Req'd)
- 5 - Deflector Post Pin (2 Req'd)
- 6 - Deflector Core
- 7 - Compression Screw
- 8 - Lever
- 9 - Release Spring
- 10 - Core Sleeve
- 11 - Sealing Assembly
- 12 - Fusible Element
- 13 - Dust Cover

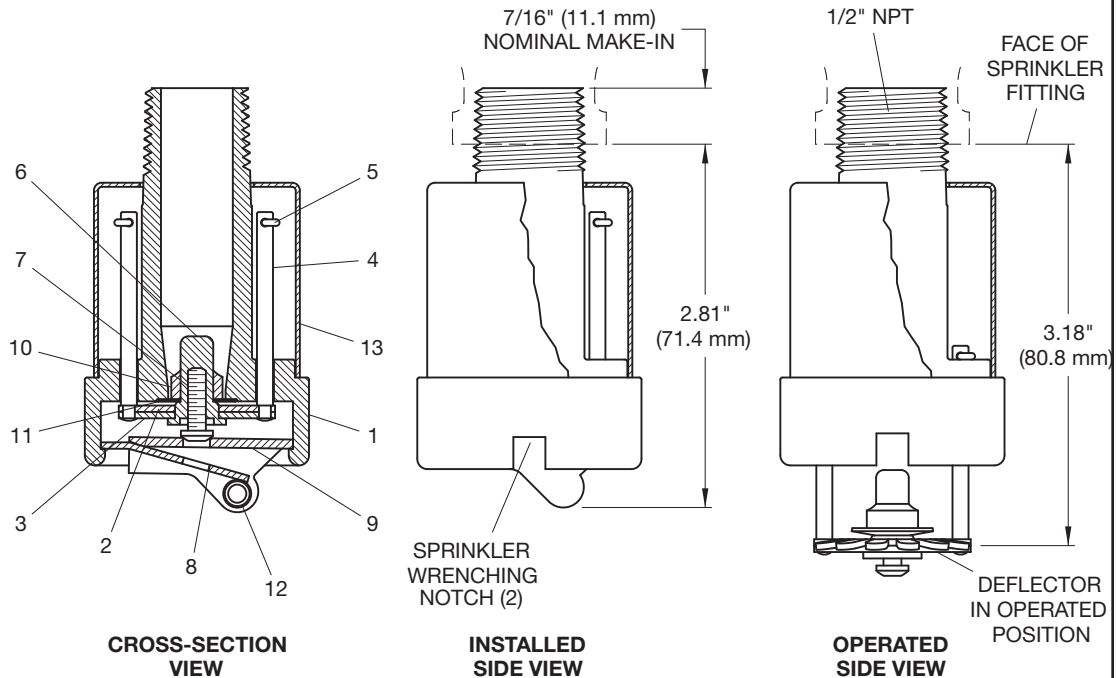

FIGURE 1
MODEL TFP PH2
INSTITUTIONAL PENDENT SPRINKLER

Only the Institutional Escutcheons shown in Figure 2 can be utilized with the Model TFP PH2. A maximum of three Model 1752 Spacers only can be utilized with Style B1 or C Institutional Escutcheons when vertical adjustment is desired.

NOTICE

The integrity of the tamper resistant design of the Institutional Escutcheons is dependent on the piping installation design. When installed properly, the Institutional Escutcheon is held fast to the mounting surface by the tightening of the sprinkler assembly into the sprinkler fitting. In order to accomplish a proper installation, the sprinkler fitting must be properly located with respect to the distance from the face of the sprinkler fitting to the face of the mounting surface (Ref. Figure 2); the sprinkler fitting being rigidly secured and held immobile; and, the center-line of the sprinkler fitting being perpendicular to the mounting surface to assure that the escutcheon sits squarely against the mounting surface around the entire perimeter of the Institutional Escutcheon.

Installation

The TYCO Model TFP PH2, 5.6 K-factor, Sprinklers must be installed in accordance with this section.

General Instructions

Refer to the Design Criteria section for important information regarding the piping installation design and its effect on maintaining the integrity of the tamper resistant design of the Institutional Escutcheons.

Obtain a 1/2 in. NPT sprinkler joint by applying a minimum-to-maximum torque of 7 to 14 lb-ft (9,5 to 19,0 N·m). Higher levels of torque can distort the sprinkler Inlet with consequent leakage or impairment of the sprinkler.

Do not attempt to compensate for improper location of the sprinkler fitting by under- or over-tightening the sprinkler. Re-adjust the position of the sprinkler fitting to suit, or increase or decrease the number of Model 1752 Spacers, as applicable.

After the installation is complete, make certain that the Institutional Escutcheon is held fast to the mounting surface and that it sits squarely against the ceiling around its entire perimeter.

Step 1. Install the TFP PH2 Sprinklers only in the pendent position and with the center-line of the waterway perpendicular to the ceiling.

Step 2. With the Institutional Escutcheon in place and with pipe thread sealant applied to the pipe threads, hand tighten the sprinkler into the sprinkler fitting.

Step 3. Wrench-tighten the Sprinkler using only the Model 1509-3 Sprinkler Wrench (Ref. Figure 4). Apply the wrenching teeth of the Sprinkler Wrench to the sprinkler wrenching notch areas (Ref. Figure 1).

Step 4. After the installation is complete, make certain that the Institutional Escutcheon is held fast to the mounting surface and that it sits squarely against the ceiling around its entire perimeter.

Care and Maintenance

The TYCO Model TFP PH2, 5.6 K-factor Sprinklers must be maintained and serviced in accordance with this section.

Before closing a fire protection system main control valve for maintenance work on the fire protection system that it controls, obtain permission to shut down the affected fire protection systems from the proper authorities and notify all personnel who may be affected by this action.

Replace sprinklers that are leaking or exhibiting visible signs of corrosion.

Never paint, plate, coat, or otherwise alter automatic sprinklers after they leave the factory. Replace modified or over-heated sprinklers.

Exercise care to avoid damage to the sprinklers before, during, and after installation. Replace sprinklers damaged by dropping, striking, wrench twisting, wrench slipping, or the like.

The owner is responsible for the inspection, testing, and maintenance of their fire protection system and devices in compliance with this document, as well as with the applicable standards of the NATIONAL FIRE PROTECTION ASSOCIATION (for example, NFPA 25), in addition to the standards of any other authorities having jurisdiction. Contact the installing contractor or product manufacturer with any questions.

Automatic sprinkler systems should be inspected, tested, and maintained by a qualified Inspection Service in accordance with local requirements and/or national codes.

Service inspections should be made on a regular basis to detect possible damage or alterations to the sprinkler and escutcheon. Inspections should include making certain that the Institutional Escutcheon is held fast to the mounting surface. Damaged or altered sprinklers are to be replaced immediately to avoid personal injury and to prevent use for causing personal injury, as well as to maintain the sprinkler system in an operative condition.

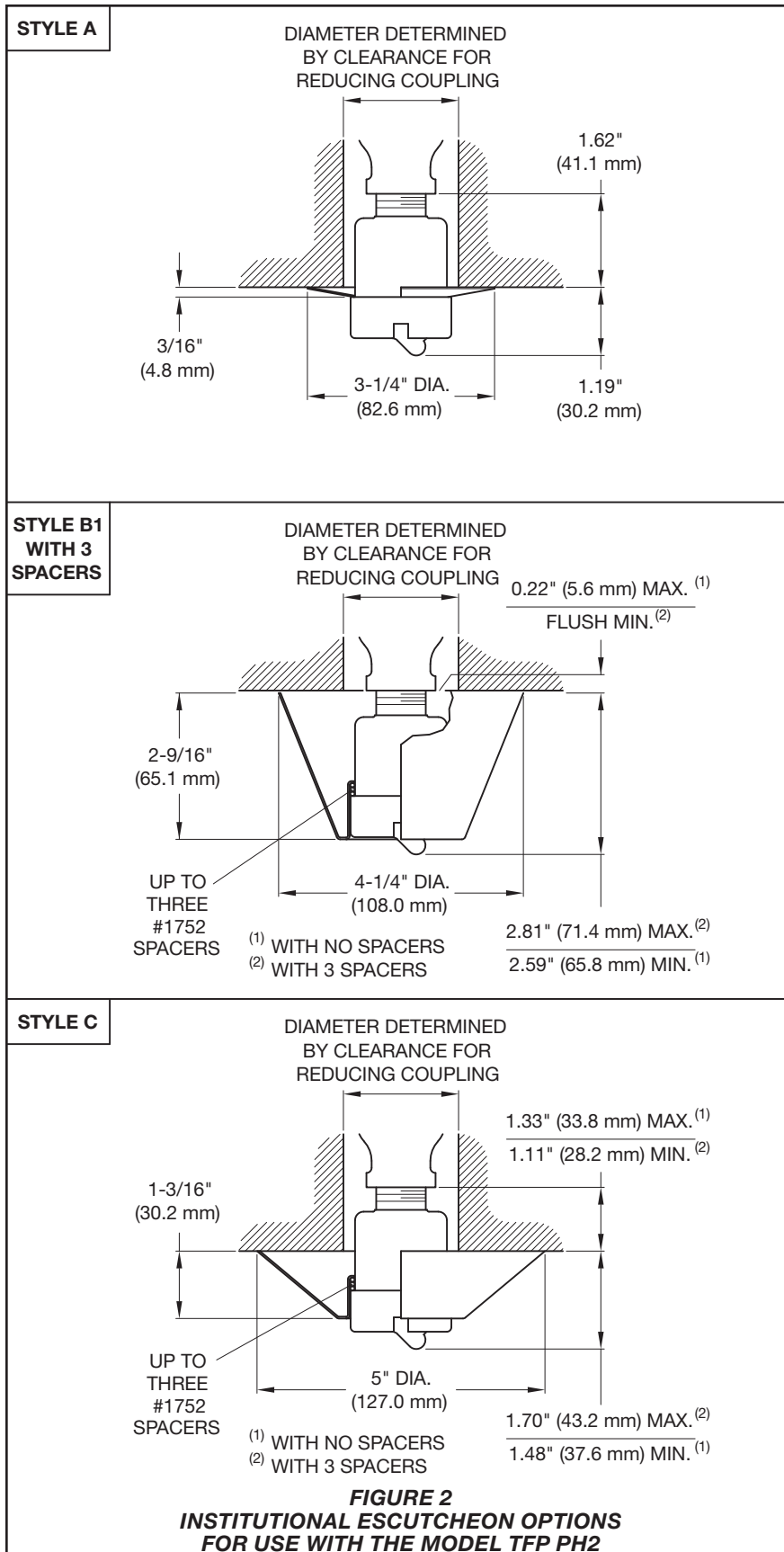

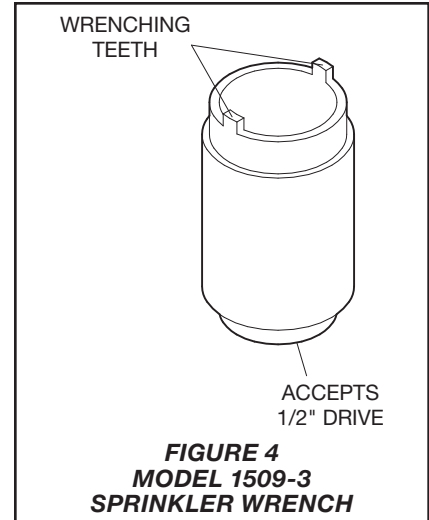
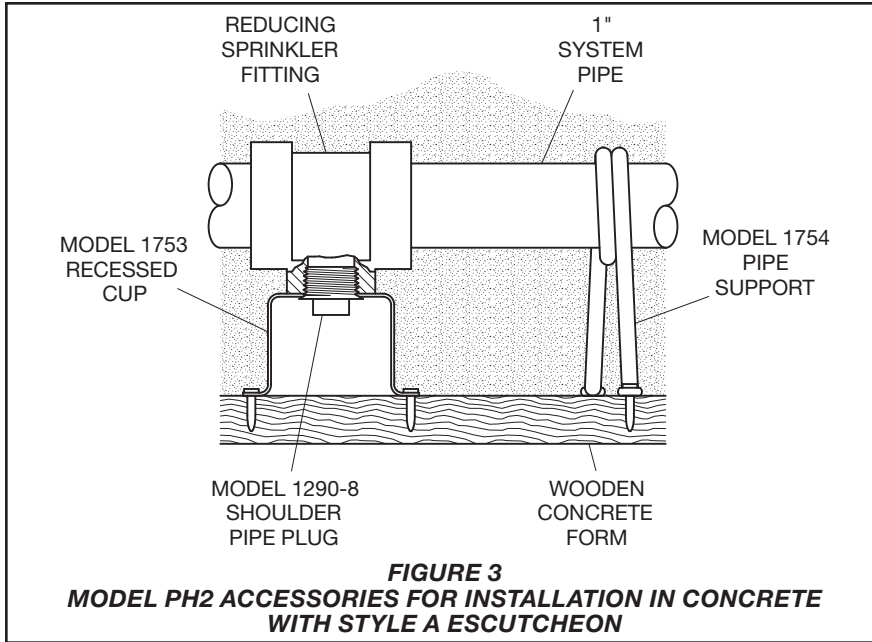

Limited Warranty

For warranty terms and conditions, visit www.tyco-fire.com.

Ordering Procedure

Contact your local distributor for availability. When placing an order, indicate the full product name and Part Number (P/N).

Sprinkler Assemblies

Specify: 5.6 K-factor, Chrome Plated, (temperature rating), Model TFP PH2 (TY3290) Institutional Pendent Sprinkler, P/N (specify):

165°F (74°C) 51-104-9-165
 212°F (100°C) 51-104-9-212

Separately Ordered Escutcheons

Specify: Style (A, B1, or C), Chrome Plated, Institutional Escutcheons, P/N (specify):

Style A 56-012-7-622
 Style B1 56-001-7-511
 Style C 56-001-7-513

Separately Ordered Wrenches

Specify: Model 1509-3 Sprinkler Wrench, P/N 56-001-5-093.

Separately Ordered Spacers for Vertical Adjustment

Specify: Model 1752 Spacers for use with Style B-1 and C Institutional Escutcheons, P/N 56-000-1-752

Separately Ordered Parts for Installation in Concrete With Type A Escutcheon

(Ref. Figure 3.)

Specify: Model 1753 Recessed Cup for use with Style A Escutcheon for installation in concrete, P/N 56-000-1-753

Specify: Model 1290-8 Pipe Plug With Shoulder for use with Style A Escutcheon for installation in concrete, P/N 56-001-2-908

Specify: Model 1754 Pipe Support for use with Style A Escutcheon for installation in concrete, P/N 56-000-1-754